

Functional description for evaluation module M2011B SMD1

MOS (PTY) LTD.

Microsystems On Silicon
Member of ELMOS Semiconductor AG

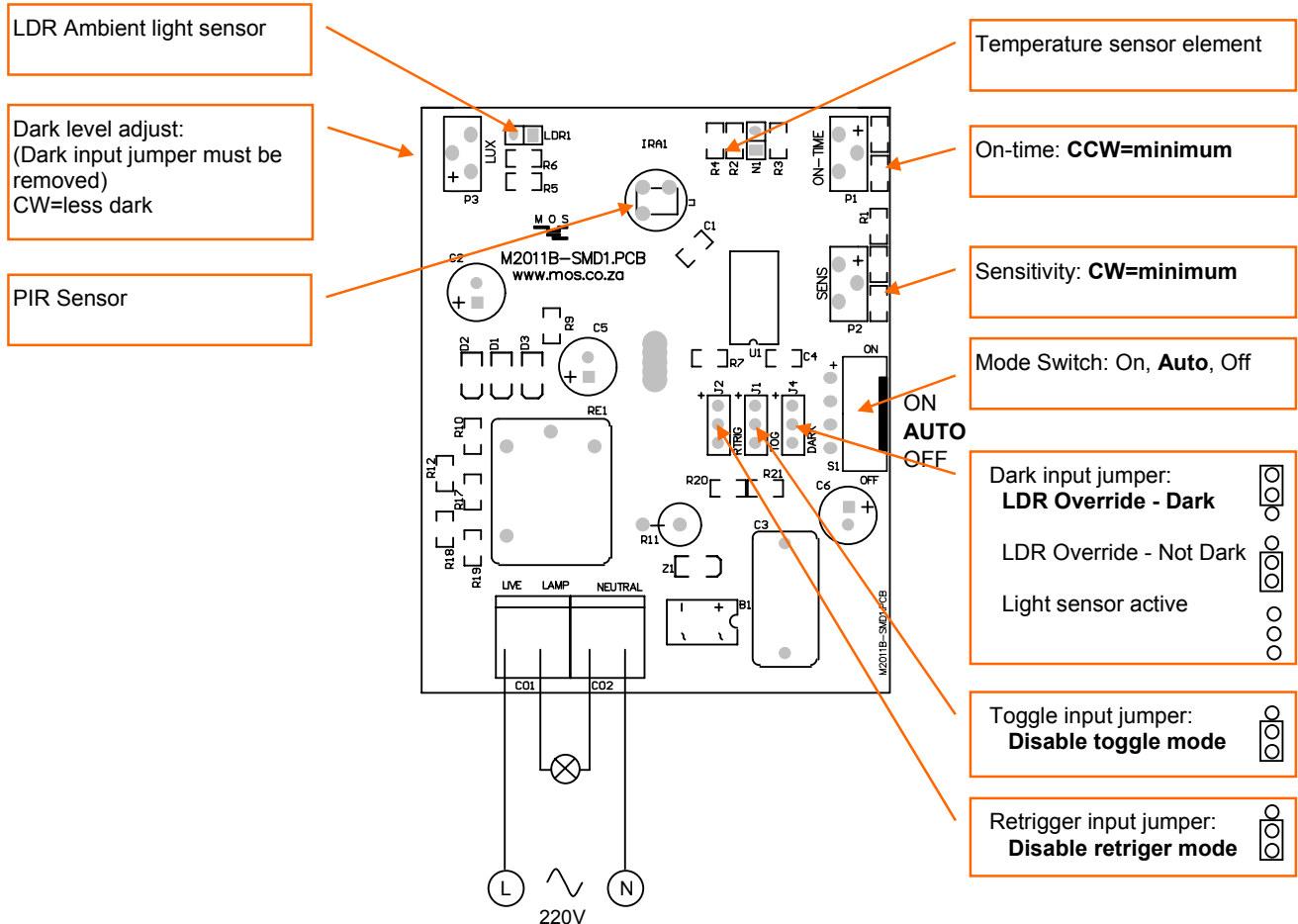

Notes:

1. For quick demo purposes: set the jumpers and the trim pots to the positions indicated in bold. Wait about 30s for the circuit to settle. Slowly turn the sensitivity trim pot CCW until the desired sensitivity level is reached.
2. CW=Clock-Wise CCW=Counter-Clock-Wise