

General Description

The E931.97 integrated circuit combines all required functions for a single chip Passive Infra Red (PIR) motion detector.

Motion detection is signaled through the push-pull REL output. A digital input OEN enables REL output.

A LED output indicates whenever the PIR Signal is above the selected threshold.

The E931.97 interfaces directly with up to two conventional PIR sensors via a high impedance differential input. The PIR signal is converted to a 15 bit digital value on chip.

The parameters for sensitivity and timing are set by connecting the corresponding inputs to DC voltages. The voltage levels on the inputs are converted to digital values with 7 bit resolution.

All signal processing is performed digitally. The E931.97 is available in TSSOP-14 and SOIC14 packages.

Applications

- ◆ PIR motion detection
- ◆ Intruder detection
- ◆ Occupancy detection
- ◆ Motion sensor lights

Features

- ◆ Digital signal processing
- ◆ On chip supply shunt regulator
- ◆ Low power consumption
- ◆ Differential PIR sensor input
- ◆ Excellent power supply rejection
- ◆ Insensitive to RF interference
- ◆ Inputs for sensitivity, on time and daylight sensor
- ◆ Outputs for relay and LED
- ◆ Instantaneous settling after power up

Intrusion Detector for Wired Alarm Systems

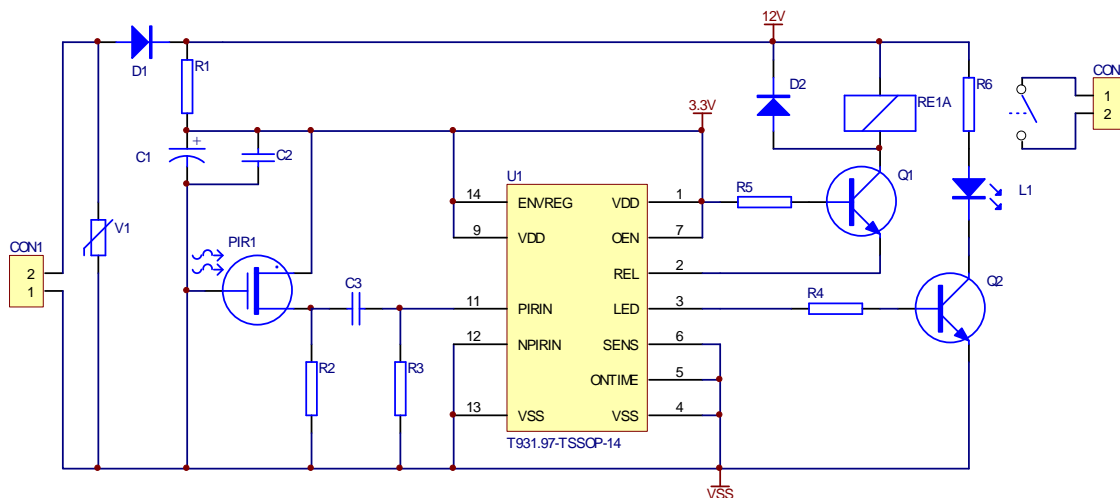

Comp	Typ. Value	Function	Note
U1	E931.97	PIR Controller IC	TSSOP-14 or SOIC-14
PIR1	LHI878	Dual Element PIR Sensor	TO-5
R1	10k	Series voltage drop resistor	$R1 < (V_{Supply} - 0.6 - V_{Reg}) / (I_{IDD} + I_{LED} / \beta_{Q2} + I_{REL} / \beta_{Q1})$
R2	100k	Pull down resistor	
R3	2.2M	Pull down resistor	
R4	22k	Base current setting resistor	$R4 = (V_{Supply} - 0.6 - V_{LED}) / (I_{LED} / \beta_{Q2})$
R5	22k	Base current setting resistor	$R5 = (V_{Reg} - V_{Q1BE}) / (I_{REL} / \beta_{Q1})$
R6	1.2k	LED drive current limiting resistor	$R6 = (V_{Supply} - 0.6 - V_{LED}) / (I_{LED})$
C1	10uF/6V	Power supply storage capacitor	
C2	100nF	Vdd-Vss Supply bypass capacitor	
C3	470nF	PIR signal bypass capacitor	
RE1	TAA1A12F00	N.O. REL	Active if no movement is detected
V1	SMBJ-12	Transorb, voltage spike protection	
Q1,Q2	BC849B	NPN transistors for LED & REL drive	
D1	1N4007	Supply Reverse connection protector diode	
D2	1N4148	Fly back protection diode	
L1		LED	

Table 1: Component Values for simple intruder detector ($V_{Supply} = 12V$)

Mains Powered Motion Sensor Light Application Circuit

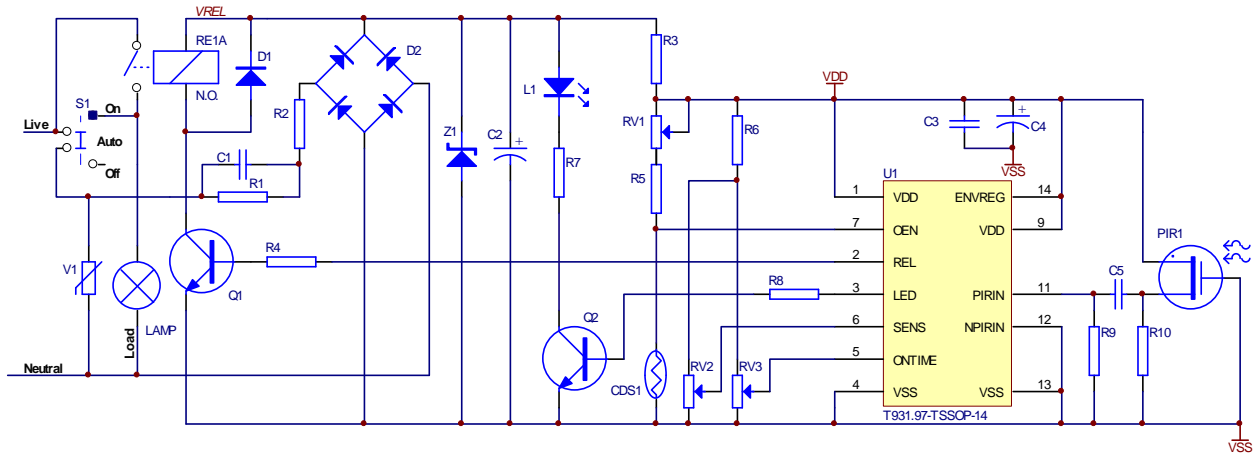

Designator	Typ. Value	Description	Note
U1	E931.97	PIR Controller IC	TSSOP-14 or SOIC14
U2	LHI878	Dual Element PIR Sensor	TO-5
R1	1M	Discharge resistor	
R2	100R	Transient protection resistor	Wire wound
R3	10k	Current limiting resistor	$R3 < (V_{REL} - V_{VDD}) / (I_{IDD} + I_{REL} / \beta_{Q1} + I_{R7} / \beta_{Q2} + I_{R5} + I_{R6})$
R4	22k	REL drive current setting resistor	$R4 = I_{REL} / \beta_{Q1}$
R5	47k	Current limiting resistor	In case $V_{CDS} = 0$ and RV1 is also turned to 0
R6	270k	Voltage divider	$V_{VDD} / 4 = (RV2 + RV3) / (RV2 + RV3 + R6)$
R7	10k	LED drive current limiting resistor	$R7 = (V_{REL} - 0.6 - V_{LED}) / (I_{LED})$
R8	100k	Base current setting resistor	$R8 = (V_{REL} - 0.6 - V_{LED}) / (I_{LED} / \beta_{Q2})$
R9	2.2M	Pull down resistor	
R10	100k	Pull down resistor	
L1		LED	LED of own choice
D1	1N4148	Fly back protection diode	
D2	DB104S	Diode bridge	
Z1	ZD47	47V Zener Diode	Choose according to RE1 voltage
CdS1		Light dependent resistor	
RV1	2.2M	OEN Voltage Adjust (Dark level)	
RV2	220k	Sensitivity adjustment	Select in conjunction with R6 and RV3
RV3	220k	On Time adjustment	Select in conjunction with R6 and RV2
V1	S10275VAC	Transorb, for high voltage spike protection	
C1	330n/230VAC	Voltage dropper capacitor	
C2	10µF/50V	Supply voltage storage	Voltage rating dependant on RE1 voltage
C3	1µF/6V	Decoupling capacitor	Ceramic, close to supply pins of device
C4	10µF/6V	Sensor supply storage	Regulator compensation capacitor
C5	470nF	PIR signal bypass capacitor	
RE1	47V	N.O. REL	High coil voltage, less drive current
S1		3 position Mains switch	

Table 2: Component Values for Motion Sensor Light

Electrical Characteristics

Absolute Maximum Ratings

Parameter	Symbol	Min	Max	Unit	Remarks
Supply Voltage	V_{DD}	-0.3	3.6	V	
Current into any pin		-100	100	mA	One pin at a time
Storage Temperature	T_{st}	-45	125	°C	

Table 3: Electrical Characteristics (Stresses beyond those listed above may cause permanent damage to the device. Exposure to absolute maximum ratings may affect the device reliability. ESD protection: all pins will be able to withstand a discharge of a 100pF capacitor charged to 1.6kV through a 1500Ω series resistor. Test method: MIL-STD-883D method 3015).

Operating Conditions ($T=25^{\circ}\text{C}$, unless stated otherwise)

Parameter	Symbol	Min	Typ	Max	Unit	Remarks
Temperature						
Operating temperature range		-25		85	°C	
Regulator						
Shunt regulator current	I_R			5	mA	
Supply current, ENREG=VDD	I_{DD}		25	30	μA	VDD < Regulator voltage, Outputs unloaded
Supply current, ENREG=VSS	I_{DD}		12	15	μA	Regulator not active, VDD=3.3V
Regulator voltage	V_{DD}	2.7	3	3.3	V	$I_R = 0.5\text{mA}$
Input OEN						
Input low voltage	V_{IL}			0.8	V	
Input high voltage	V_{IH}	0.9			V	
Input Current	I_I	-1		1	μA	$V_{SS} < V_{IN} < V_{DD}$
Input ENVREG						
Input low voltage	V_{IL}			0.2	V_{DD}	
Input high voltage	V_{IH}	0.8			V_{DD}	
Input Current	I_I	-1		1	μA	$V_{SS} < V_{IN} < V_{DD}$
Outputs REL, LED						
Output current high	I_{OH}			-10	mA	$V_{OL} > (V_{DD} - 1\text{V})$
Output current low	I_{OL}	10			mA	$V_{OL} < 1\text{V}$
Inputs SENS, ONTIME						
Input voltage range		0		V_{DD}		Adjustment between 0V and ¼ VDD
Input leakage current		-1		1	μA	
PIRIN / NPIRIN Inputs						
PIRIN /NPIRIN input resistance to V_{SS}		20			GΩ	-60mV < VIN < 60mV
PIRIN /NPIRIN input resistance differential		40			GΩ	-60mV < VIN < 60mV
PIRIN input voltage range		-60		60	mV	
Oscillator and Filter						
LPF cutoff frequency			7		Hz	
HPF cutoff frequency			0.44		Hz	
On chip oscillator frequency	F_{CLK}		64		kHz	
System Clock	C_G		$F_{CLK}/2$			

Table 4: Operating Conditions

Detailed Description

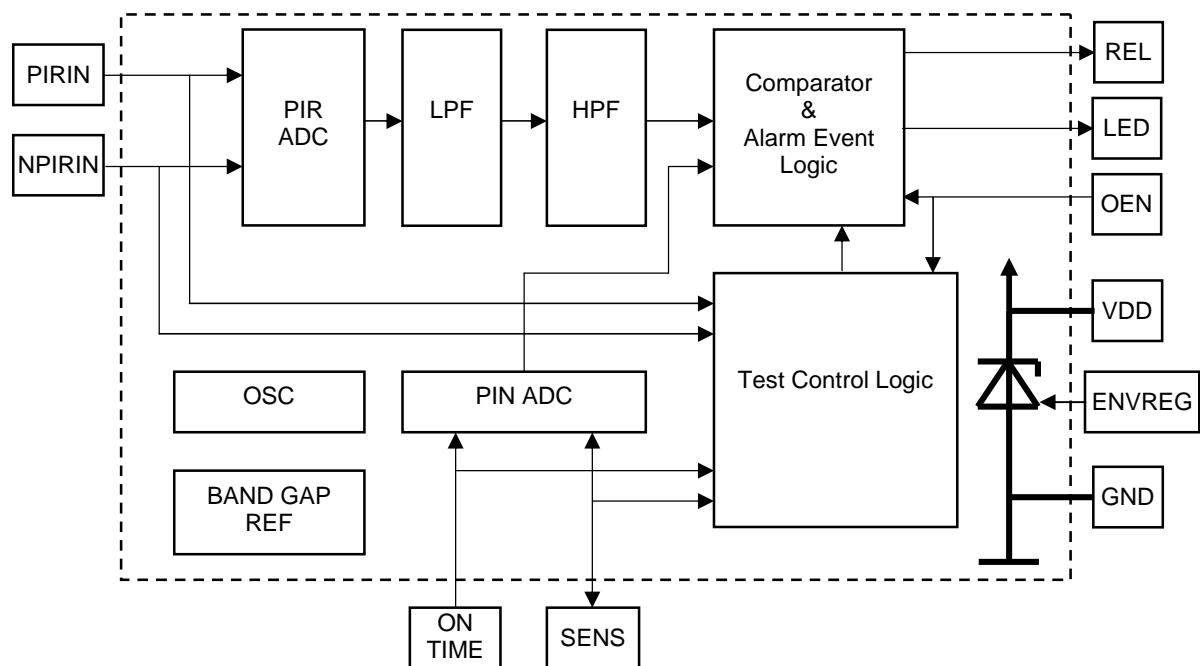

Fig 1: Block diagram of E931.97

PIR Sensor Input

A differential input stage provides for the connection of up to two PIR sensors. The analog to digital converter generates a digital signal from the voltage level measured between the PIRIN and NPIRIN pins.

A band gap reference ensures a temperature and supply voltage independent gain.

Voltage Regulator

The integrated shunt voltage regulator can be activated by the user through the ENVREG input. The E931.97 can be operated directly from batteries or regulated supply voltages ranging from 2.7V to 3.6V. In this case, the voltage regulator needs to be switched off and the user can benefit from the very low current consumption.

In applications with higher voltages, the user would activate the on chip shunt regulator, which generates a stable supply voltage of 3V for the E931.97 and the PIR detector. The V_{DD} pin requires a bypass capacitor to V_{SS} . The reference for the shunt regulator is taken from the integrated band gap reference.

Oscillator

The IC contains an on chip low power oscillator. The frequency is set to 64kHz. The timing signals and

cutoff frequencies of the digital filters are derived from this frequency.

Band-Pass Filter

A 2nd order low-pass filter with a cut-off frequency of 7Hz eliminates unwanted higher frequency components. This signal is then passed to a 2nd order high pass filter with a 0.4Hz cut-off frequency.

Alarm Event Processor

The signal from the band pass filter is rectified. When the signal level exceeds the set sensitivity threshold, an internal pulse is generated. A second pulse is counted, when the signals changes sign and exceeds the threshold again.

Whenever 2 pulses appear within 4s, the REL output is activated. The LED output is activated, whenever the signal level is above the sensitivity threshold.

Large signals in excess of 5 x the selected threshold result in immediate activation of the relay output.

The voltage applied to the ONTIME input determines how long the REL output stays active. The REL output remains active from the first alarm condition to the last alarm condition plus the time selected with the ONTIME input.

On Time

A voltage applied to the ONTIME input set the time the REL output is active with a single trigger event. Any voltage above VDD/4 will select the maximum on time.

Pin voltage	PIN ADC count	ON Time in seconds	ON Time
$V_{DD} * 1/128$ or less	0	2	2 sec
$V_{DD} * 3/128$	1	4	4 sec
$V_{DD} * 5/128$	2	6	6 sec
$V_{DD} * 7/128$	3	8	8 sec
$V_{DD} * 9/128$	4	16	16 sec
$V_{DD} * 11/128$	5	33	32 sec
$V_{DD} * 13/128$	6	49	49 sec
$V_{DD} * 15/128$	7	66	1 min 5 sec
$V_{DD} * 17/128$	8	131	2 min 11 sec
$V_{DD} * 19/128$	9	262	4 min 22 sec
$V_{DD} * 21/128$	10	393	6 min 33 sec
$V_{DD} * 23/128$	11	524	8 min 44 sec
$V_{DD} * 25/128$	12	1049	17 min 28 sec
$V_{DD} * 27/128$	13	2097	34 min 57 sec
$V_{DD} * 29/128$	14	3146	52 min 25 sec
$V_{DD} * 31/128$ or above	15	4194	1 hour 10 min

Table 5: DC input voltages and parameter values

Sensitivity

A voltage applied to the SENS input sets the threshold used to detect a PIR signal between the PIRIN and NPIRIN inputs. VSS selects the minimum threshold voltage. Any voltage above VDD/4 will select the maximum threshold, which is the least sensitive setting for PIR signal detection.

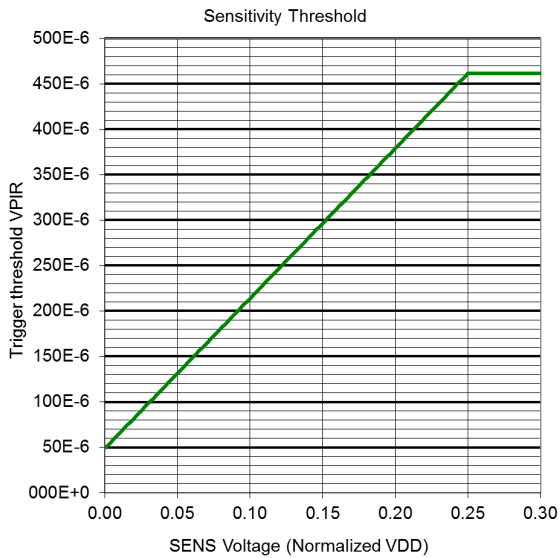

Graph 1: PIR voltage trigger threshold vs. SENS pin voltages normalized to VDD.

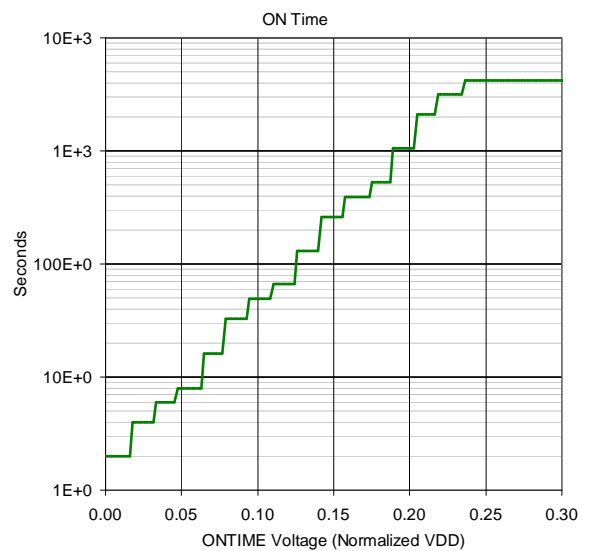

Graph 2: REL Output On Time in seconds vs. ONTIME pin voltages normalized to VDD.

Pin Diagram

Pin Name	Pin Number	Description
V _{DD}	1, 9	Supply voltage, shunt regulator
REL	2	REL Output (push-pull)
LED	3	LED Output (push-pull)
V _{SS}	4	Negative supply voltage
ONTIME	5	On time selection input
SENS	6	Sensitivity selection input
OEN	7	(> V _{THR_H} <= V _{DD}) : REL output is enabled (>= V _{SS} < V _{THR_L}) : REL output is disabled
N.C.	8, 10	Not connected
PIRIN	11	PIR sensor input
NPIRIN	12	Negative PIR sensor input
V _{SS}	13	Negative supply voltage
ENVREG	14	Regulator Enable, connect to V _{DD} to enable regulator, Connect to V _{SS} to disable regulator for low current battery based applications, where V _{DD} will be less than 3.3V.

Table 6: Pin Out

Contact Information

Microsystems On Silicon (PTY) Ltd.

Pretoria, South Africa
Tel: +27 (12) 348 8367
Fax: +27 (12) 348 1790
Email: sales@mos.co.za

Visit our website for the latest information